

DATA SHEET
Lembar data produk

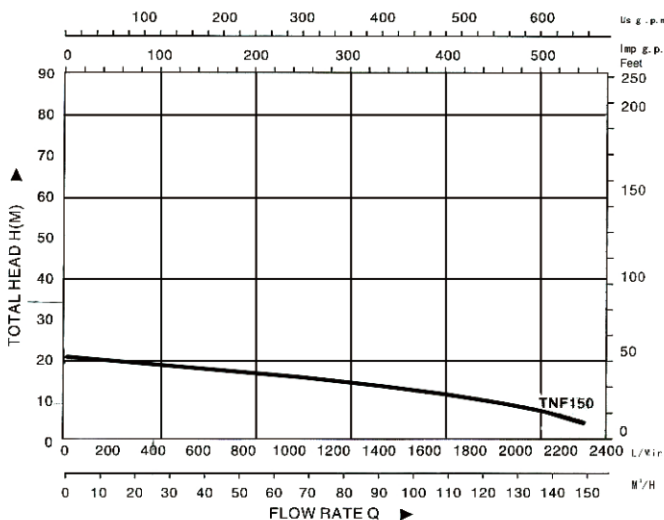

THF 150
Centrifugal Pump



Spesification:

Device application / Aplikasi	Water Distribution / Distribusi Air
Power / Listrik	7.5 kW / 10 HP (3 phase)
Inlet / Outlet	2" x 2"
Max. Suction / Daya Hisap Maks.	7 m
Max. Head / Head Maks.	40 m
Max. Flow	400 l/min
Max. Capacity / Kapasitas Maks.	400 l/min (on H : 20 m)
Fluid rate temperature / Temperatur Cairan	Up to +35°
Max. ambient temperature / Temperatur Maks.	Up to +40°
Construction Material / Bahan Dasar Pompa	- Pump Body : Cast Iron - Shaft : 45# Steel
Pump Feature / Fitur Pompa	- Brass impeller
Pump Dimension / Dimensi Pompa	62 x 31 x 39 cm

Pump Structure

1. Pump body
2. Impeller
3. Nut
4. Shaft Key
5. Locking Ring
6. Mechanical Seal
7. Motor Front Cover
8. Bracket
9. Bolt
10. Water Washer
11. Bearing
12. Rotor

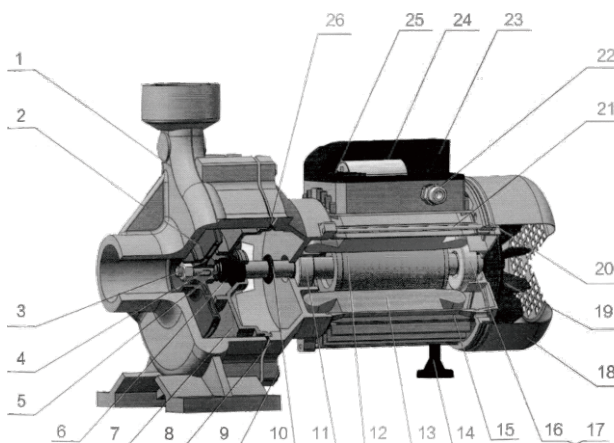

14. Motor Foot
15. Motor Body
16. Bearing
17. Spring Washer
18. Fan Cover
19. Fan
20. Motor End Cover
21. Bolt
22. Cable Protector
23. Terminal Cover
24. Capacitor
25. Terminal Block
26. O-ring